

CDI P/N: 134-6456-18

This item replaces the following P/N's: 96455A18.

Warning! This product is designed for installation by a professional marine mechanic. CDI cannot be held liable for injury or damage resulting from improper installation, abuse, neglect or misuse of this product.

INSTALLATION

1. Disconnect the battery cable and remove the flywheel according to the service manual.
2. Disconnect the trigger lead from the TPM.
3. Disconnect the trigger linkage arm from the trigger.
4. Remove the bushing from the old trigger arm and install it in the new trigger arm.
5. Remove the stator bolts and lay the stator out of the way.
6. Remove the old trigger and install the new trigger and the stator according to the service manual.
7. Connect the trigger linkage to the bushing and then connect the trigger lead to the TPM.
8. Replace the flywheel according to the service manual and reconnect the battery cable.
9. Verify and adjust ignition timing as needed according to the service manual.

TROUBLESHOOTING

No fire or Intermittent on One or More Cylinders:

1. Using a set of piercing probes, check the trigger Resistance and DVA output as given below:

Wire Color	Check to Wire Color	OEM Resistance	CDI Resistance	DVA Reading
Purple wire	Blue	1100-1400	800-1050	4V or more
White wire	Red	1100-1400	800-1050	4V or more
Brown wire	Yellow	1100-1400	800-1050	4V or more

2. Using a set of piercing probes, check the trigger voltage going to the CDM's:

Wire Color	Check to Wire Color	OEM Resistance	CDI Resistance	DVA Reading
Purple wire	Engine GND	Open	Open	.5V or more
White wire	Engine GND	Open	Open	.5V or more
Brown wire	Engine GND	Open	Open	.5V or more
Blue wire	Engine GND	Open	Open	.5V or more
Red wire	Engine GND	Open	Open	.5V or more
Yellow wire	Engine GND	Open	Open	.5V or more

3. The connection guide below will assist you in locating areas where problems can occur. Remember a short in either #1, #2 or #3 can cause either #4, #5 and #6 not to have spark.

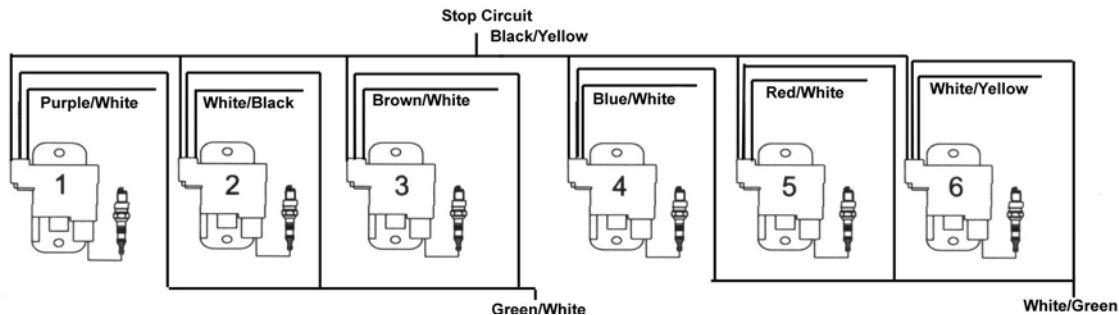

Thank you for using CDI Electronics

1/07/2010